

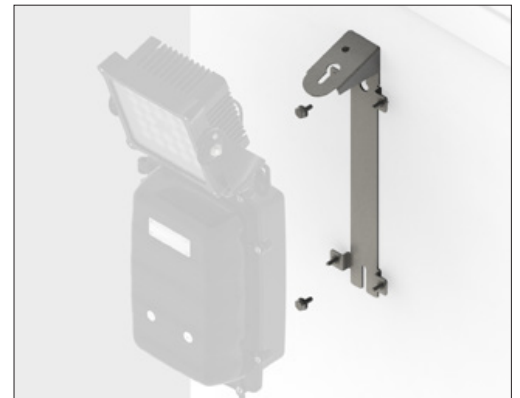

ENCLOSURE AND LUMINAIRE WALL MOUNTING BRACKET

Dimensions

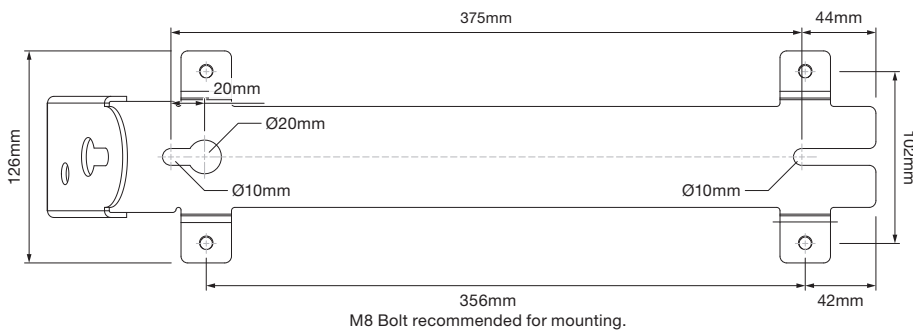

Description

Enclosure and luminaire wall mount bracket.

Technical Specifications

Suitable for	Coupling the Coolon 036AL power supply enclosure, CP9 and CP12 luminaire
Mounting	2 x M8 Bolts (not included)
Weight	1.2kg

Ordering Example

ACC	-	WMB	-	BOLT	-	036AL	-	SS
		WMB Wall Mounting Bracket		BOLT M10 T-Bolt		036AL Power Supply Aluminium Enclosure		SS Stainless Steel 304