



MOBILE PLANT LIGHTING

PERFORMANCE, RELIABILITY, SAFETY

MOBILE PLANT LIGHTING

STACKER RECLAIMERS, EXCAVATORS, ENGINE BAYS & SNAKE PITS + MANY MORE APPLICATIONS

As infrastructure is being pushed to its limits, mining companies are looking for new ways to improve performance, increase safety and reduce environmental impact.

How can mining companies increase productivity and safety, while maintaining operational profitability?

The answer lies in maintaining safety and production efficiency at their optimum levels. While a certain amount of service outage is expected for repairs and maintenance, companies cannot afford the waste and extra costs associated with using second-rate tools. Industry applications have proven that only purpose-built mining equipment can survive the harsh operating demands of a mine site – and lighting is no exception.

Coolon LED lighting products are renowned in the industry for being reliable, efficient and unbreakable. Coolon prides itself on being at the leading edge of design and innovation, and providing solutions that others may consider “impossible”. Every fitting is produced and tested extensively. There are no design short-cuts, no inferior components, and no manufacturing compromises.

Since the birth of the high power LED, Coolon has been designing, manufacturing and supplying the mining industry with high performing and reliable LED solutions. Coolons’ extensive Light Emitting Diode (LED) technologies know how, world class R&D and field studies examining the extreme operating environments of mobile plant and equipment, have culminated in the design and manufacture of unbreakable luminaires.

MOBILE PLANT LIGHTING

STACKER RECLAIMERS, EXCAVATORS, ENGINE BAYS & SNAKE PITS + MANY MORE APPLICATIONS

Robust

The unit is built to withstand vibration, shock, impact, chemicals and severe temperature variation.

Instantaneous

LED lights switch on instantly to 100% output, which means no downtime waiting for lights to warm up.

Pleasant

Flickering light can result in headaches and tiredness. Coolon's lights do not produce any visible flicker.

Warm CCT Light Options

Where white dust is present, "flashback" can occur if using cool white light. Using a warm white light as an alternative reduces flashback, making the work environment more comfortable.

Safe

Conventional lamp based lighting systems have a shorter life span, consume more power and require substantially higher operating and starting voltages, when compared to LEDs. Coolon LED lights are powered by extra low voltages (ELV), resulting in improved safety and lower installation and certification costs.

Customisable

Custom solutions and product variants are unheard of with most mining product suppliers. While Coolon's product range is adaptable to most applications, we recognise that one size does not fit all. The R&D team thrives on challenges, and there is no problem too big or too complex. Coolon's lights are designed and manufactured in Australia, and our knowledgeable support service is only a phone call away. With proven industry results, Coolon Mobile Plant lighting is the right solution when safety and reliability cannot be compromised.

LIGHTING DESIGN

FIT-FOR-PURPOSE SOLUTIONS



Coolon is dedicated to providing the most fit-for-purpose solution for every application. By identifying the specific requirements of applications in advance Coolon customises each design and provide a tailored lighting simulation that demonstrates the required lighting levels achievable. Lighting designs remove doubt allowing you to get it right first time, minimizing trial time, downtime and risk.

Aerial View

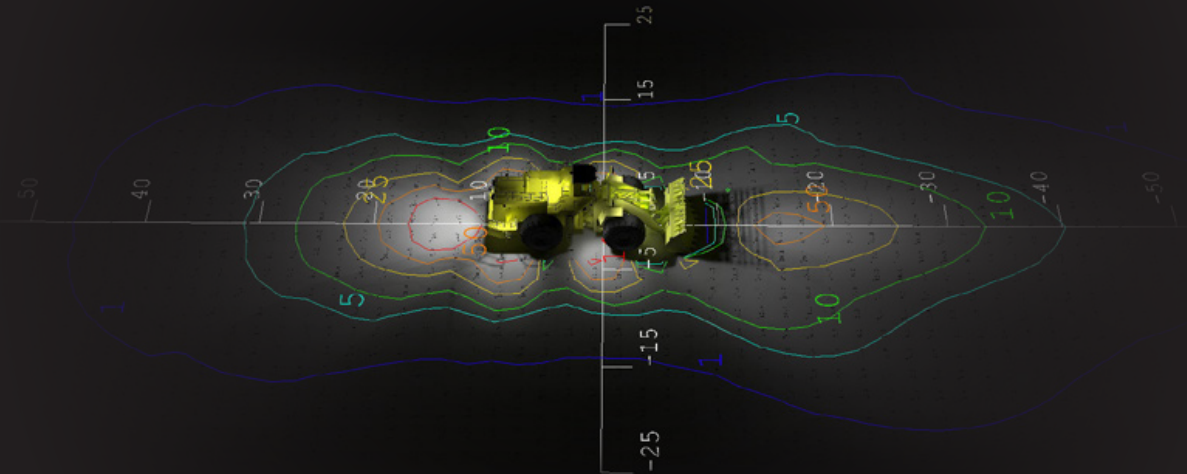

Front/Side View

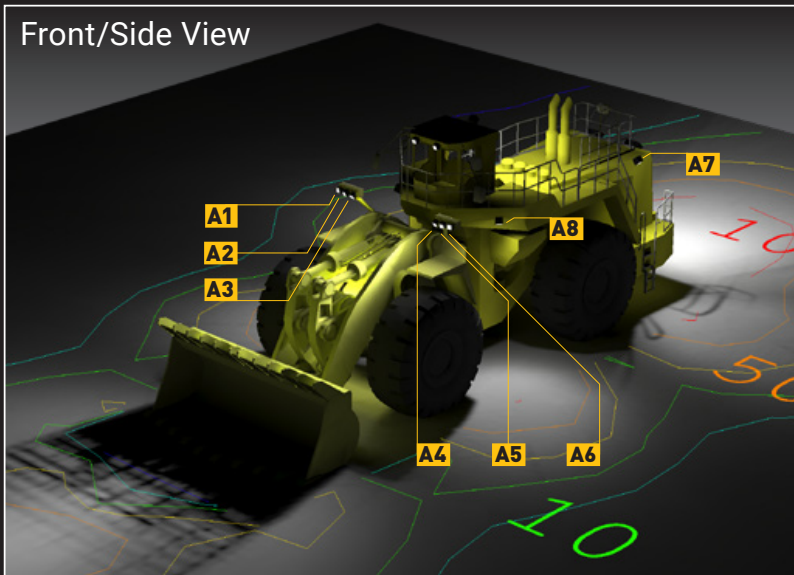

Back/Side View

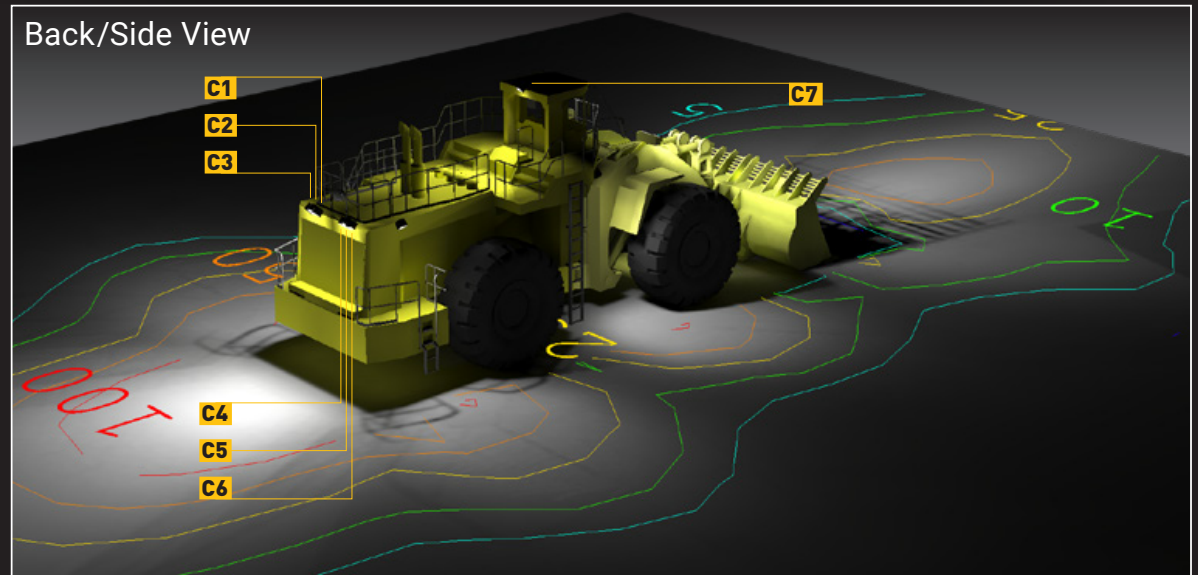

LUMINAIRE FEATURES

OUR PRODUCTS TICK ALL THE BOXES



Comfortable light

Zero flickering. Reduced eye strain and increased productivity. Optional warm colour reduces “flashback” associated with cold white light and dust



Cool to touch

Low surface temperature. Prevents caked dirt build-up. No need to replace lens.



Zero EMI

No disruption to communication. No interference with control and data acquisition systems. Improved safety and productivity.

Long life

State of the art thermal management. Integral control systems. Over 50,000 operating hours to 70% residual light output



Rated IP66

Protected against dust and water. Can be high pressure washed.



Simply unbreakable

Multi-layered protection using industrial grade coatings. Resistant to vibration, shock, impact, chemicals and severe temperature variation.

Instant on

Instant on to 100% output. No downtime waiting for lights to warm up. Optional sensor switch for saving energy



Flexible application

Designed to fit many machines and applications. Increased user safety due to extra low voltages (ELV). Input voltage options range from 12VDC to 34VDC

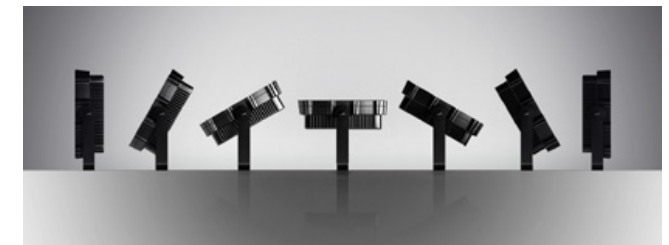

Unrestricted mounting position

Coolon Luminaires achieve the specified life and performance irrespective of the burning position. Position the luminaire and aim at any angle required.

MACHINE LIGHT (MC22)

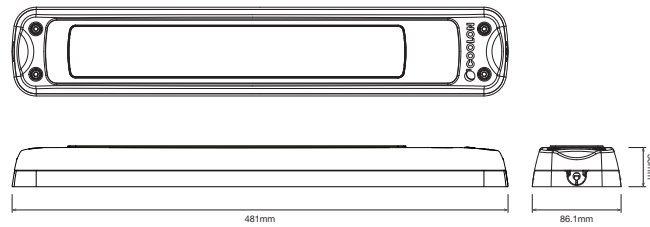

CP12 - SMALL

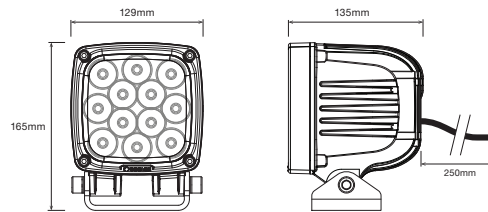

CP14UG - UNDERGROUND

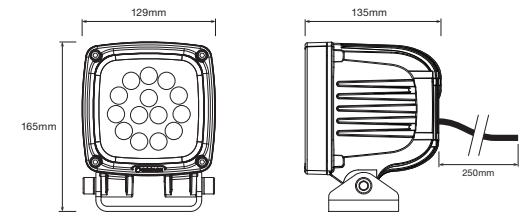

Power	25W @ 24VDC / 19.5W @ 12VDC	48W / 60W	35W @ 26VDC / 50W @ 12VDC
Suggested Applications	Excavator Engine Bay Fluorescent Replacement Hydraulic Snake Pit Machine House Lighting Machine Operator Cabin Switch Board Lighting	Bulldozers Drill Rigs Excavators Flood Lights Graders Lighting Towers Light Vehicles / 4WD Processing Plants Trucks Warehouses	Underground Drill Rigs (Jumbos) Underground General Lighting Underground Haul Trucks Underground Wheel Loaders (Boggers) Other EMI Sensitive Applications
Voltage Range	23 – 27VDC / 12 – 16VDC	21 – 34VDC	23 – 28VDC / 10 – 15VDC
Weight	1.4kg	2.1kg	2.1kg
Overview	Compact design makes the Machine Light perfect for confined spaces. Available in the Extra Low Voltage Emergency Kit. Kit includes: 2 x Machine Light 12V, Mobile Plant Emergency Pack, 2 x MC22 extension loom, Em loom and 3 way junction.	Designed to match the physical characteristics of most factory fitted halogen work lights. Same size, same shape. Greater area coverage and longer light distance. Available in Extra Low Voltage or Dimming (0-10V) configurations.	Purpose built for lighting installations on underground mining machines. Produces NO EMI, it is virtually undetectable and is guaranteed to not cause any interference with vital communications and data logging equipment.

CP24 - MID-RANGE

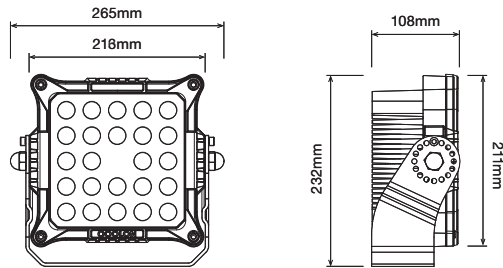

CP56 - LARGE

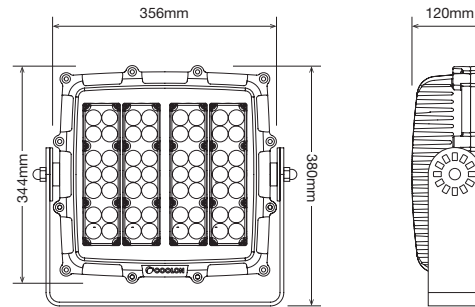

Power

85W @ 24VDC

270W @ 24VDC

Suggested Applications

Bulldozers
 Drag Lines
 Excavators
 Trucks
 Processing Plants
 ROM Pads
 Stacker / Reclaimers
 Low voltage mobile towers

Crushers
 Drag Lines
 Earthmoving Machinery
 Elevating Work Platforms
 Excavators
 Flood Lighting
 Gantry Cranes

Voltage Range

21 – 34VDC

21 – 34VDC

Weight

4kg

12kg

Overview

Perfect balance of power and size.
 Light weight and versatile.

Powerful and robust, ideal for large applications.
 High lumen output flood light.
 Range of power options to suit requirements.



THE COOLON EXPERIENCE

FIT-FOR-PURPOSE SOLUTIONS

Unmatched customer support

Dealing directly with the manufacturer ensures the fastest enquiry response time. Custom solutions can be developed with no delay or loss of information due to third parties.

Engineers on site familiar with the site requirements can work directly with Coolon's engineers to develop the right solution: we speak the same language.

Purpose-built

Coolon's Mobile Plant lighting range is designed specifically for mining applications. Resistance to vibration, shock, impact, chemicals and severe temperature variations has been factored into each design.

Rigorously tested

100% of the units produced are tested for operation, electrical safety, thermal and environmental characteristics, light distribution and colour spectrum. All product design parameters are validated to ensure product performance and reliability.

Proven industry results

The ultimate test for any mining fitting is conducted on-site, in the real environment. Our industry reputation speaks for itself.

Quality certification

Coolon is ISO9001 certified for the design, manufacture and sales of LED luminaires for the industrial, architectural and commercial markets.

Proudly Made in Australia

Engineered to perfection, using only the highest quality components and skilled labour. Made to meet or exceed Australian standards. Proud to support and service the toughest industry on earth.

Website

www.coolon.com.au

Email

support@coolon.com.au

Phone

1300 287 533 / +613 8681 3633

Follow Us



Search: Coolon LED Lighting