

WDN-140

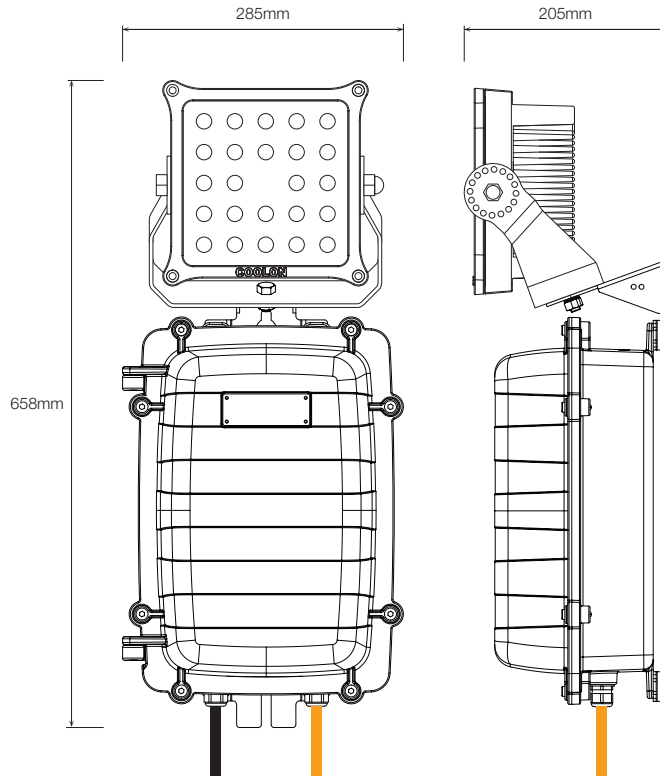

ASSEMBLY KIT

The assembly kit includes the following components

Wall Mount Bracket

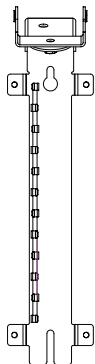

Power Supply & Enclosure

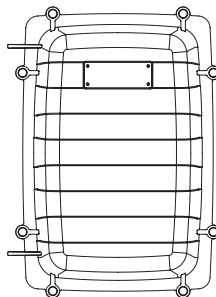

WDN-140 LED Luminaire

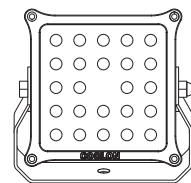

Mounting Hardware

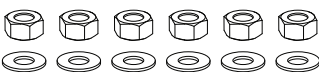

6X M8 nyloc nuts
6X M8 washers
(4 sets used for mounting and 2 spare)



2X M6x20 hexagonal cap screws
for power supply lid supplied as spare

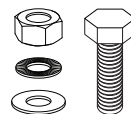

1X M10 nylock nut
1X M10 washer
1X M10 Nord-Lock washer
1X M10x25 hex bolt



2X Zip Ties



1X 12x9.2 plastic grommet

MOUNTING INSTRUCTIONS

Step 1

Mount the wall bracket using the slots provided

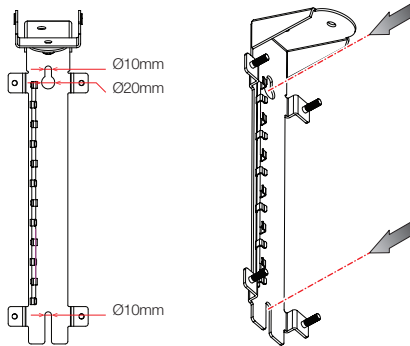

Step 2

Mount the luminaire (A) and feed the cable through the grommet provided (B) and secure into the cable retaining clip (C) on the bracket.

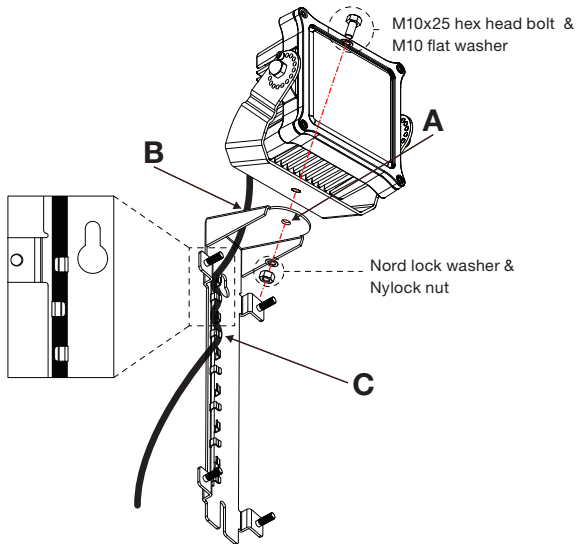

Step 3

Mount the power supply enclosure to the wall mount bracket using the four M8 nylock nuts and washers.

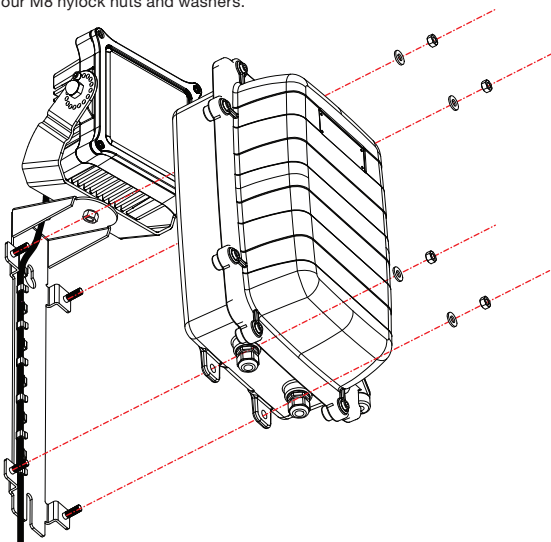

Step 4

Feed the cables through the cable glands and connect as shown below, making sure polarities are adhered to. Once the cables are positioned as required secure the cable gland nut sufficiently for an adequately sealed connection.

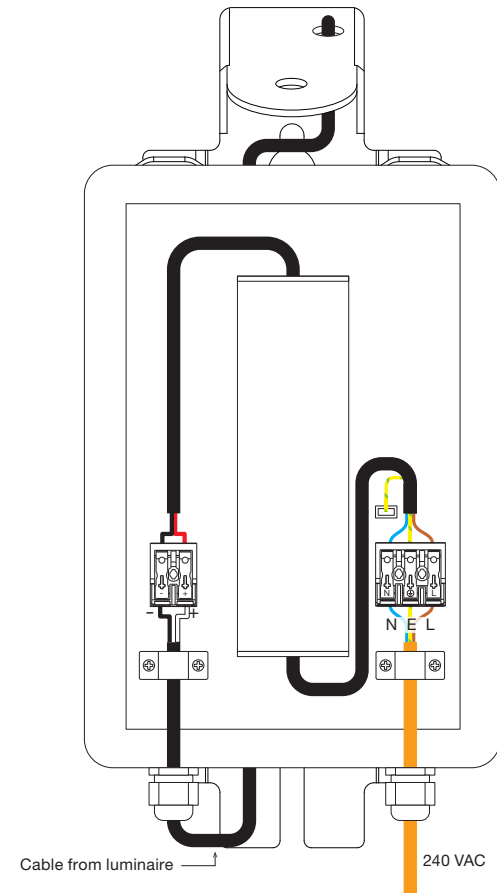

Step 5

The power supply enclosure can now be closed and secured using the eight M6x20 hexagonal cap screws.

